

TOP VIEW
SCALE: 1/30

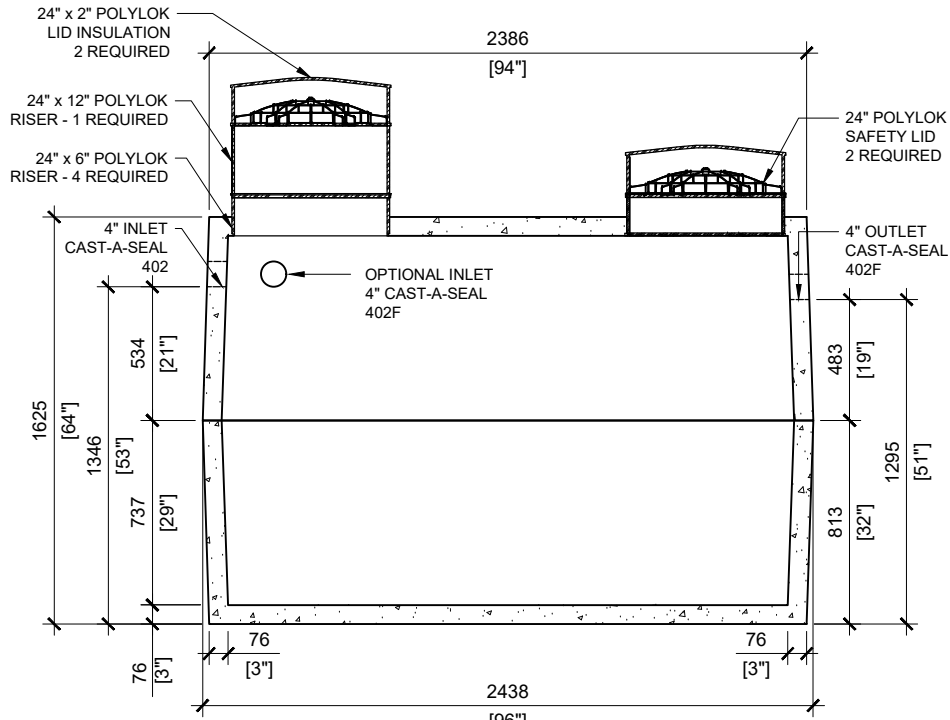

SECTION A
SCALE: 1/30

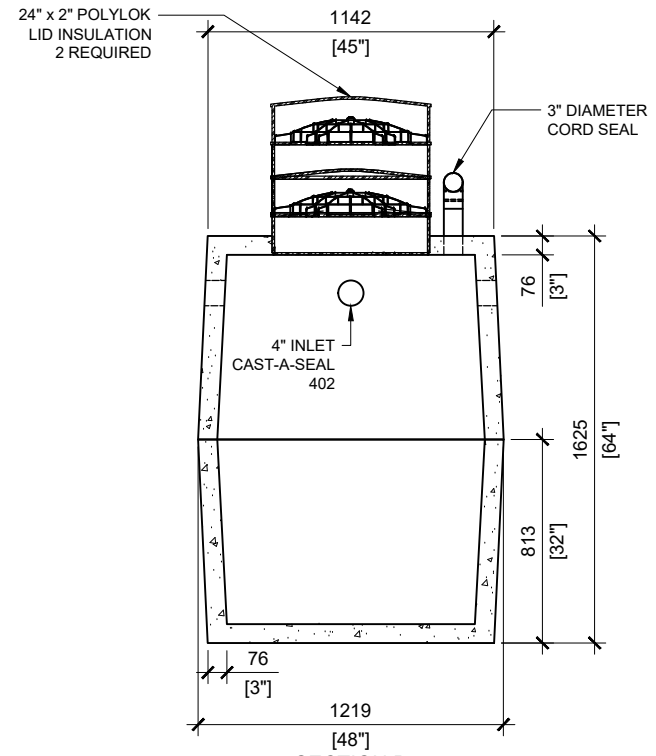

SECTION B
SCALE: 1/30

GENERAL NOTES:

1. UNITS ARE SEALED WITH "NON-TOXIC" BUTYL TAPE AT THE JOINTS
2. DELIVERY IS MADE BY CRANE-EQUIPPED TRUCKS
3. EXCAVATION MUST BE READY, SAFE AND ACCESSIBLE FOR UNLOADING FROM THE REAR OF THE TRUCK.
4. MIN OVERHEAD CLEARANCE OF 18FT (5.5 METRES) IS REQUIRED
5. ALL UNITS MUST BE HANDLED WITH PROPER LIFTING EQUIPMENT
6. MAXIMUM BURIAL DEPTH = 1 METRE IN FIRM SOIL AWAY FROM ANY VEHICULAR TRAFFIC
7. POLYLOK SAFETY LIDS INSTALLED IN BOTH OPENINGS AS PER CSA-B66-21
8. 24"x12" POLYLOK RISER WITH ELECTRICAL SPLICE BOX SUPPLIED BY WATERLOO AT THE OUTLET



MANUFACTURED:
LINDSAY, ON
1-800-655-3430

CONCRETE: 35MPa at 28 days/5000PSI
AIR ENTRAINMENT: 5-8%
REINFORCEMENT: STEEL TO CSA CAN
A23.1 / A23.3 G30.18 Fy=400MPa

UNIT WEIGHT: 5,720lbs / 2,594kg

DRAWN BY:
PRASHAN

DATE:
FEB/2024

WATERLOO PT-2900

2,900 LITRES