

- GENERAL NOTES:**
1. ALL MATERIALS AND WORKMANSHIP CONFORM TO THE OBC2012
  2. STRUCTURE HAS BEEN DESIGNED IN ACCORDANCE WITH PART 4 OF THE OBC 2012
  3. THE STRUCTURE IS TO BE FOUNDED ON FREE DRAINING NON-FROST SUSCEPTIBLE MATERIAL WITH A SOIL BEARING CAPACITY OF NO LESS THAN 30kPa
  4. CONCRETE ADHESIVE IS TO BE APPLIED TO THE JOINTS BETWEEN THE WALLS AND THE FLOOR/ROOF SLABS
  5. CONCRETE MATERIALS CONFORMS TO CSA A23.1
  6. REINFORCING STEEL CONFORMS TO CSA G30.18/ W.W.M. CONFORMS TO CSA G30.5

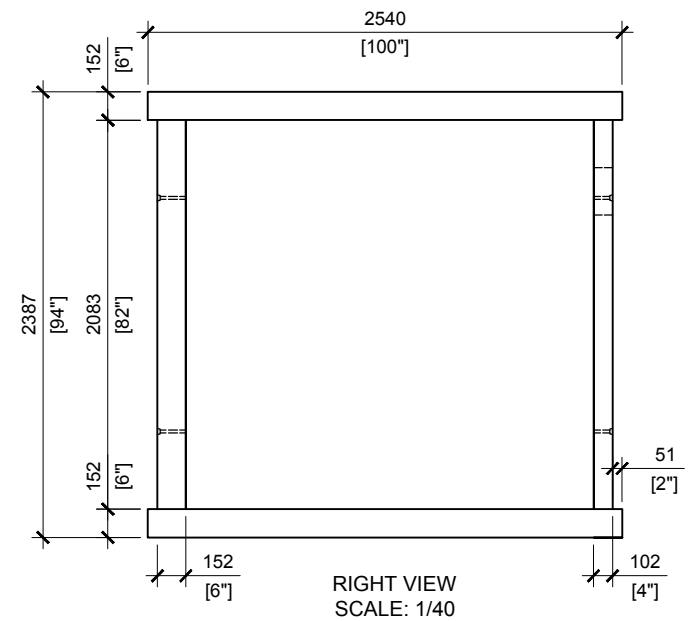
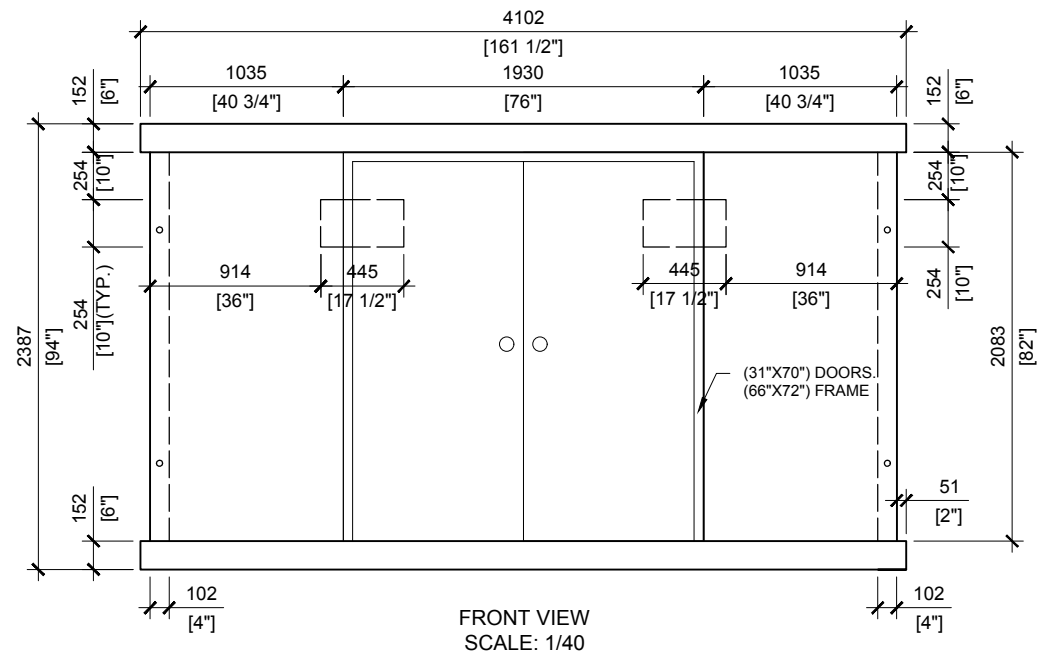

**MANUFACTURED:**  
BROOKLIN, ON  
1-800-655-3430

**CONCRETE:** 35MPa / 5,000PSI  
**AIR ENTRAINMENT:** 6-8%  
**REINFORCEMENT :** STEEL TO CSA  
CAN A23.1 / A23.3, G30.18 Fy=400MPa

**WEIGHT:** FLOOR: 8,411lbs / 3,815kg  
BACK: 4,484lbs / 2,035kg  
2 SIDES: 2,448lbs / 1,110kg  
2 FRONTS: 1,740lbs / 790kg  
ROOF: 8,411lbs / 3,815kg

**DRAWN BY:**  
S.RIMLAND  
**DATE:**  
AUG/2017

# MODEL 105

PRECAST CONCRETE UTILITY BUILDING  
**TYPICAL USE:** ABOVE GROUND ELECTRICAL ROOM